

## Mann+Hummel FM200 Oil Cleaning Centrifuge Maintenance Procedure

Applicable for the FM200-11/12/15/18 series Centrifuge Range

The Mann+Hummel FM200 Oil Cleaning Centrifuge should be cleaned at regular intervals ensuring that the thickness of the dirt deposit inside the rotor does not exceed approximately 35mm. This operation is normally carried out after a specified period of operational use and may be combined with other maintenance procedures.

### Maintenance Procedure

1. Stop the flow of oil to the centrifuge by either stopping the engine or closing the centrifuge isolating valve (if fitted). Ensure the centrifuge has come to a complete stop before proceeding.
2. Remove the band clamp, unscrew the cover nut and remove the centrifuge cover assembly.
3. Allow the oil to drain out of the rotor assembly. This may be assisted by raising the rotor on the spindle. Withdraw the rotor assembly vertically upwards from the spindle. The rotor should be removed and replaced on the spindle with care in order to ensure that the rotor bearings are not damaged.
4. Secure the rotor assembly on the rotor disassembly tool (Part N<sup>o</sup>. 6890690601). Unscrew the rotor cover nut and separate the rotor cover from the rotor body.
5. Remove the standtube.
6. Remove sludge deposits from the inside of the rotor cover using a spatula. Clean the rotor components using a suitable cleaning fluid. Ensure that all rotor components (including the two nozzles located in the rotor body), are thoroughly cleaned and free from debris before reassembly.
7. Examine the rotor assembly O ring for damage and renew if necessary (Kit N<sup>o</sup>. 6899075001).
8. Fit a new paper insert (Part N<sup>o</sup>. 6890322001) into the rotor cover.
9. Reassemble the rotor assembly ensuring that the rotor cover slot and rotor body pin are aligned. **Do not interchange rotor covers.**
10. Replace the rotor on the spindle and check that the rotor spins freely.
11. Examine the centrifuge body O ring for damage and renew if necessary (Kit N<sup>o</sup>. 6899075001).
12. Replace the centrifuge cover and fasten the centrifuge cover nut hand tight.
13. Replace the band clamp and tighten hand tight. The band clamp must be securely fitted during operation of the centrifuge.
14. With the centrifuge running, check all joints for leaks.

### Important Notes

The Mann+Hummel Oil Cleaning Centrifuge is designed to provide extended service without the need to replace major components. However, after extended periods of operation wear and damage to the centrifuge spindle and rotor assembly may become evident. For this reason it is recommended that the centrifuge spindle and rotor assembly bearings are visually inspected for damage and wear during the cleaning process. If excessive wear or bearing play is evident, the rotor assembly and/or the centrifuge body assembly should be replaced.

All FM200 centrifuge assemblies are fitted with a cut off valve (C.O.V.), which is located in the filter body. The C.O.V. is designed to protect the engine by stopping the supply of lube oil to the centrifuge at start-up and during periods when the oil pressure is below the C.O.V. rating. This item is intended to provide maintenance free operation for extended periods and should only be disassembled and inspected for damage if a problem becomes evident.

### Maintenance Action

#### Every Oil Drain Interval:

- Clean Rotor Assembly / Replace Paper Insert (Part N<sup>o</sup>. 6890322001).
- Inspect Centrifuge Body O Ring & Rotor Body O Ring. Replace if Damaged (Kit N<sup>o</sup>. 6899075001).
- Check Cover Nut O Ring for leaks and replace if necessary (Kit N<sup>o</sup>. 6899075001).
- Inspect Rotor Bearings for wear and replace Rotor Body Assembly if necessary.
- Inspect Spindle for wear and replace Centrifuge Body Assembly if necessary.

#### Engine Overhaul:

- Replace Centrifuge

Please note that this should be used as a guide only. Maintenance intervals for the centrifuge are dependant on a number of factors and differ with engine type and operational environment.

## OIL CONDITIONING SYSTEMS SPARE PARTS LIST

MANN+HUMMEL

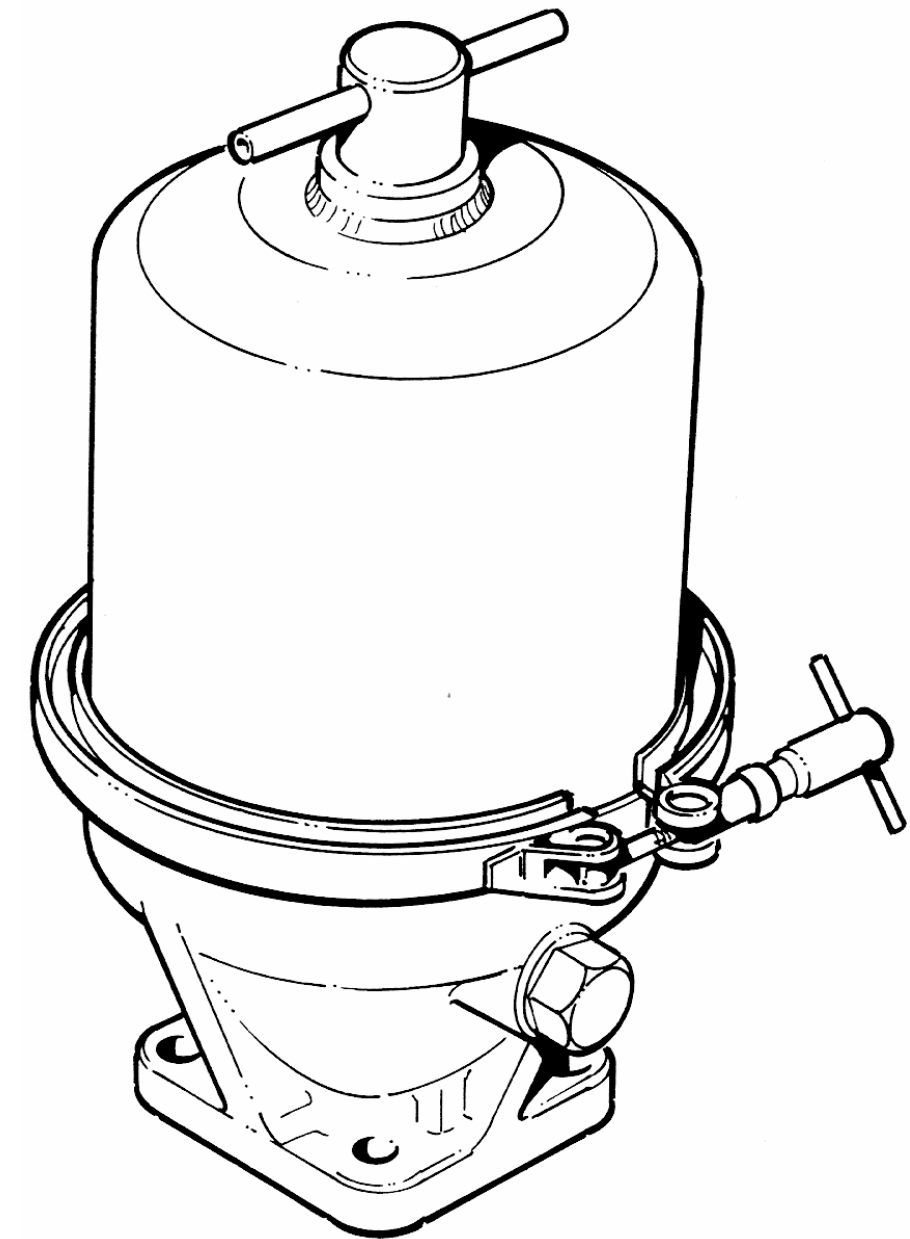

## FM200 - 11/12/15/18 SERIES

# Spare Parts List

FM200	PART No.	QTY	FM200-11 (6899110601)	FM200-12 (6899110701)	FM200-15 (6899110901)	FM200-18 (6899115901)
CUT OFF VALVE RATING (BAR)			2.5	2.1	2.5	1.5
OIL INLET THREAD SPEC.			1/2" BSP	7/8" UNF	M22 x 1.5	M22 x 1.5

BODY ASSEMBLY	PART No.	QTY	FM200-11 (6899110601)	FM200-12 (6899110701)	FM200-15 (6899110901)	FM200-18 (6899115901)
	6899023701	1	•			
	6899023801	1		•		
	6899024401	1			•	
	6899029501	1				•

ROTOR ASSEMBLY	PART No.	QTY	FM200-11 (6899110601)	FM200-12 (6899110701)	FM200-15 (6899110901)	FM200-18 (6899115901)
	6899411701	1	•	•	•	•
NOZZLE	6890490402	2	•	•	•	•
BEARING TUBE ASSEMBLY	6899053601	1	•	•	•	•
STAND TUBE	6890313601	1	•	•	•	•
CIRCLIP	6890121816	1	•	•	•	•
PIN	6890102116	1	•	•	•	•
ROTOR COVER NUT	6890184701	1	•	•	•	•
PAPER INSERT	6890322001	1	•	•	•	•
STIFFENER PLATE	6893312201	1	•	•	•	•

COVER ASSEMBLY	PART No.	QTY	FM200-11 (6899110601)	FM200-12 (6899110701)	FM200-15 (6899110901)	FM200-18 (6899115901)
	6899034301	1	•	•	•	•
COVER SUB-ASSEMBLY	6899060501	1	•	•	•	•

BAND CLAMP	PART No.	QTY	FM200-11 (6899110601)	FM200-12 (6899110701)	FM200-15 (6899110901)	FM200-18 (6899115901)
	6890332301	1	•	•	•	•

FM200 KITS	PART No.	QTY	FM200-11 (6899110601)	FM200-12 (6899110701)	FM200-15 (6899110901)	FM200-18 (6899115901)
CUT OFF VALVE KIT	6899074501	1	•		•	
CUT OFF VALVE KIT	6899074601	1		•		
CUT OFF VALVE KIT	6899713401	1				•
COVER NUT FIXING KIT	6899074901	1	•	•	•	•
SEALS KIT	6899075001	1	•	•	•	•

MANN + HUMMEL (UK) LTD.  
Units 11 - 15 Chard Business Park  
Leach Road, Chard  
Somerset, TA20 1FA  
Tel: +44 (0) 1460 238900  
Fax: +44 (0) 1460 238997

MANN+HUMMEL FILTER TECHNOLOGY (S.E.A)  
PTE LTD  
3 Toh Tuck Link  
#03-02/03 German Districentre  
Singapore 596228  
Tel: +65 (6465) 11 28

ROTOR ASSEMBLY  
6899411701

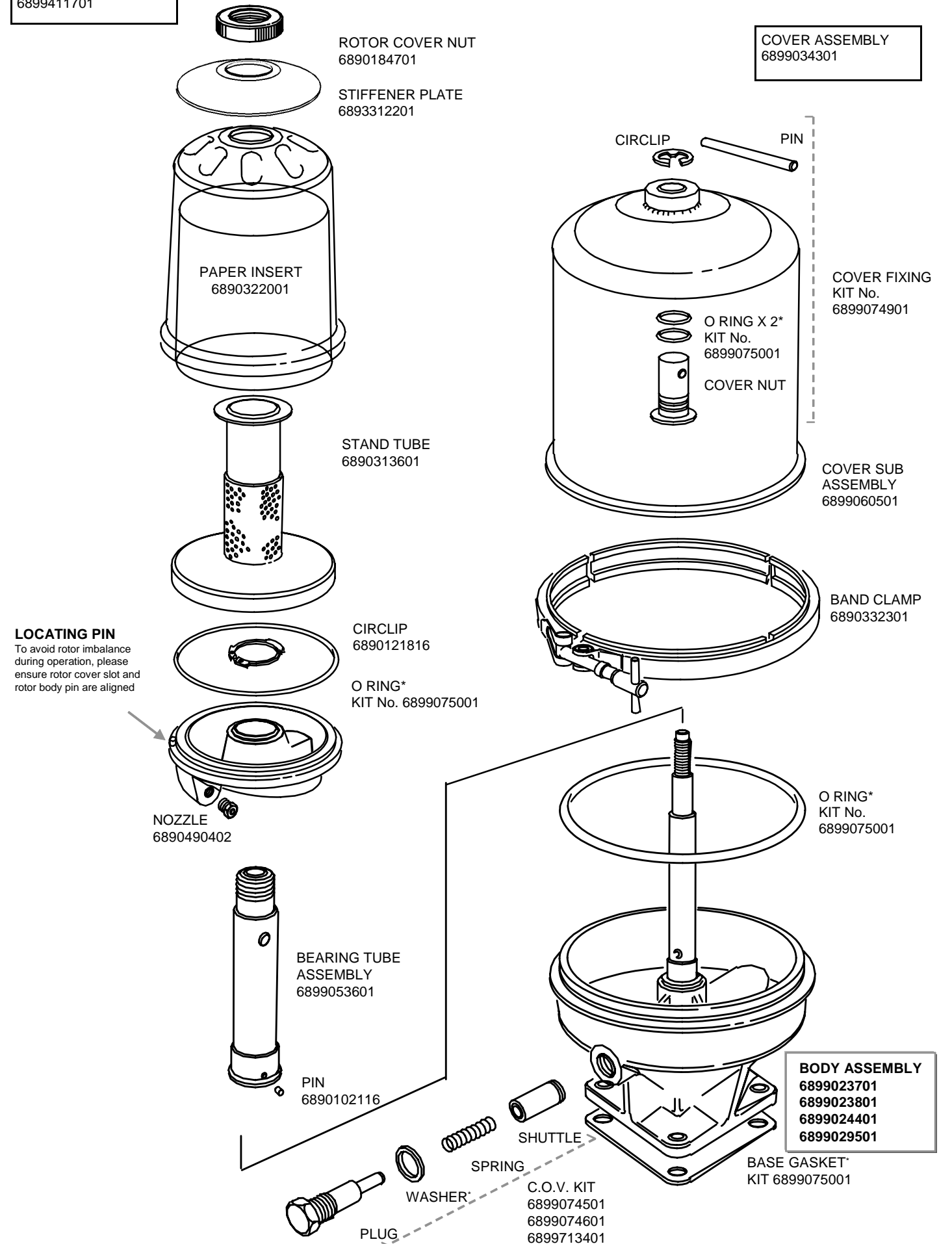

\*SEALS KIT (6899075001) COMPRISES OF: C.O.V. WASHER, BODY O-RING, ROTOR O-RING, COVER O-RING x 2, BASE GASKET