

MANN+HUMMEL FM400 Oil Cleaning Centrifuge Maintenance Procedure

Applicable for the FM400-23/23PB/24

The MANN+HUMMEL FM400 Oil Cleaning Centrifuge should be cleaned at regular intervals ensuring that the thickness of the dirt deposit inside the rotor does not exceed approximately 45mm. This operation is normally carried out after a specified period of operational use and may be combined with other maintenance procedures.

Maintenance Procedure

1. Stop the flow of oil to the centrifuge by either stopping the engine or closing the centrifuge isolating valve (if fitted). Ensure the centrifuge has come to a complete stop before proceeding.
2. Remove the band clamp, unscrew the cover nut and remove the centrifuge cover assembly.
3. Allow the oil to drain out of the rotor assembly. This may be assisted by raising the rotor on the spindle. Withdraw the rotor assembly vertically upwards from the spindle. The rotor should be removed and replaced on the spindle with care in order to ensure that the rotor bearings are not damaged.
4. Unscrew the rotor cover nut on the rotor assembly, for this two 60mm sockets (3/4" drive) are required. A service tool is available (p.n. 6890691301) to aid disassembly. This is to be used in conjunction with the two 60mm (3/4" drive) sockets.
5. Carefully remove the rotor cover.
6. Carefully remove the rotor tube. This should ensure the majority of sludge remains within the rotor tube.
7. Remove the paper insert from the rotor tube and clean any remaining sludge by using a wooden spatula or other non-damaging tool.
8. Carefully remove the separation cone from the rotor.
9. Clean the rotor tube, separation cone, rotor body and other parts using a suitable cleaning liquid.
10. Check the rotor nozzles to ensure free passage of oil.
11. Examine the top and bottom bearings of the rotor for excessive wear.
12. Replace the separation cone, making sure that it is properly located on the rotor base. If the separation cone does not fit properly, ensure the location area is free from dirt and refit the separation cone.
12. Examine the rotor assembly O rings for damage, replace if necessary or at intervals of 2500 hours (Kit N°. 6899717001).
13. Locate the separation cone into the rotor base and assemble the rotor tube onto the rotor base.
14. Fit new paper insert (Part N°. 6893322601) into the rotor tube.
15. Complete the re-assembly of the rotor by replacing the rotor cover on to the bearing tube attached to the rotor base and tighten the rotor cover nut to a torque of 40 Nm (29.5 lbft).
16. Examine the centrifuge body and spindle for signs of damage or wear and replace if necessary. **Do not try to repair.**
17. Replace rotor on spindle and check that the rotor spins freely.
18. Examine the centrifuge body O rings for damage, renew if necessary or at intervals of 2500 hours (Kit N°. 6899717001).
19. Replace the centrifuge cover and tighten cover nut to a torque of 5-7Nm.
20. Replace the band clamp and tighten nut to a torque of 5-7Nm. **The band clamp must be securely fitted during operation of the centrifuge.**
21. Re-check cover nut tightening torque (5-7 Nm).
22. With the centrifuge running, check all joints for leaks. Replace any worn components or leaking seals (seals Kit N°. 6899717001).

Important Notes

The Mann+Hummel Oil Cleaning Centrifuge is designed to provide extended service without the need to replace major components. However, after extended periods of operation wear and damage to the centrifuge spindle and rotor assembly may become evident. For this reason it is recommended that the centrifuge spindle is checked for wear and looseness and replace the filter body assembly if necessary. Also visually inspect the rotor assembly bearings for damage and wear during the cleaning process. If excessive wear or bearing play is evident (greater than 0.3mm clearance on either journal bearing), the bearing tube assembly and/or the centrifuge body assembly should be replaced.

The FM400-23/23PB/24 centrifuge assembly is fitted with a cut off valve (C.O.V.) which is located in the filter body. The C.O.V. is designed to protect the engine by stopping the supply of lube oil to the centrifuge at start-up and during periods when the oil pressure is below the C.O.V. rating. This item is intended to provide maintenance free operation for extended periods and should only be disassembled and inspected for damage if a problem becomes evident.

Maintenance Action

Every Oil Drain Interval:

- Clean Rotor Assembly / Replace Paper Insert (Part N°. 6893322601)
- Inspect Centrifuge Body O Ring & Rotor Body O Ring. Replace every 2500 hours or if damaged (Kit N°. 6899717001)
- Check Cover Nut O Rings for leaks, replace every 2500 hours or if necessary (Kit N°. 6899717001)
- Inspect Rotor Bearings for damage and wear and replace Bearing Tube Assembly if necessary.
- Inspect Spindle for wear and looseness and replace Centrifuge Body Assembly if necessary

Engine Overhaul:

- Replace Centrifuge.

Please note that this should be used as a guide only. Maintenance intervals for the centrifuge are dependant on a number of factors and differ with engine type and operational environment.

6893329101-03

OIL CONDITIONING SYSTEMS SPARE PARTS LIST

MANN+HUMMEL

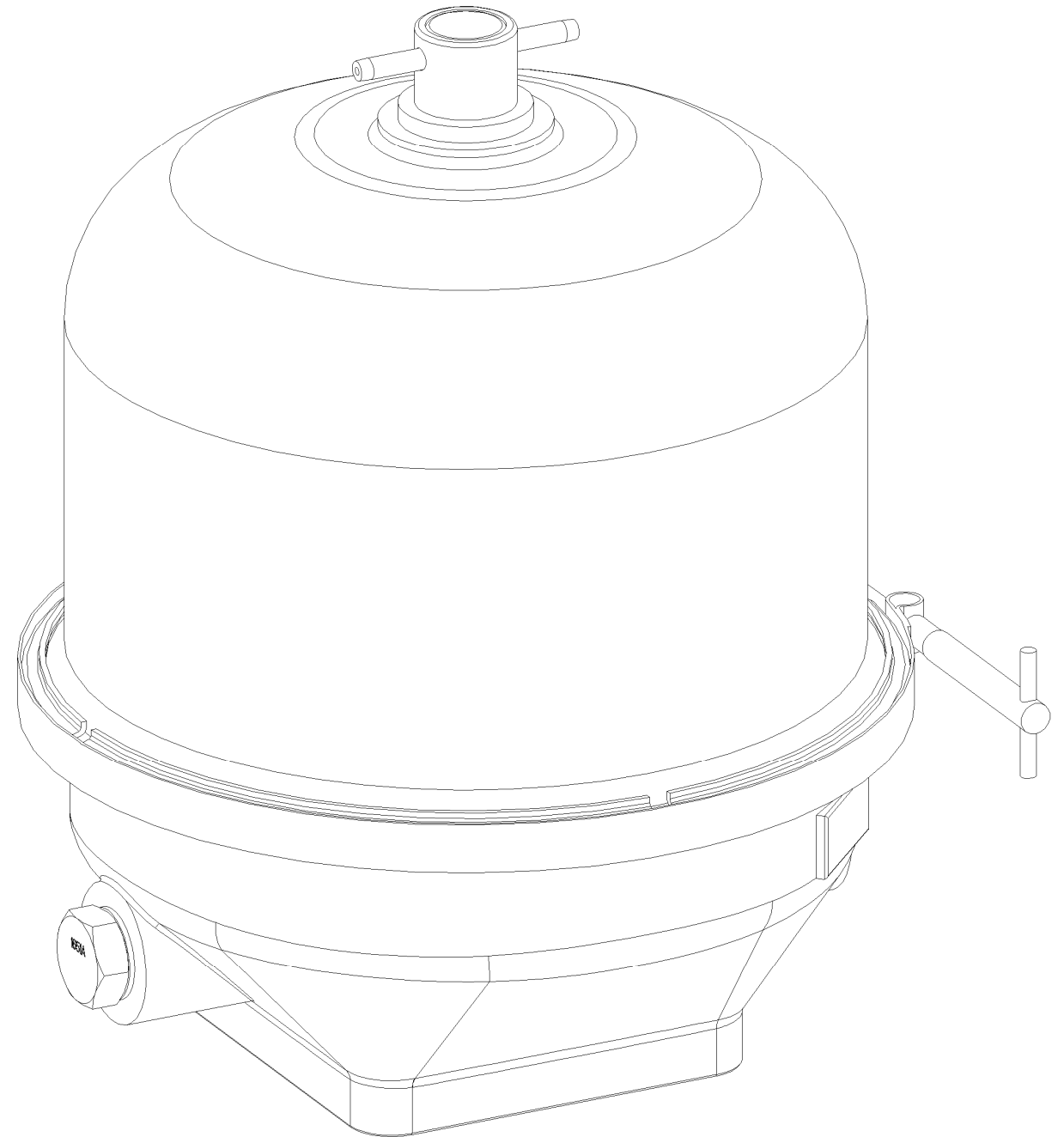

FM400 - 23/23PB/24

Spare Parts List

FM400	PART No.	QTY	FM400-23 (6899138801)	FM400-23PB (6899138301)	FM400-24 (6899138701)
CUT OFF VALVE RATING (BAR)			2.5	2.5	2.5
OIL INLET THREAD SPEC.			3/4" BSP	3/4" BSP	1 5/16" UNF

BODY ASSEMBLY	PART No.	QTY	FM400-23 (6899138801)	FM400-23PB (6899138301)	FM400-24 (6899138701)
	6899221801	1			
	6899220901	1			

ROTOR ASSEMBLY	PART No.	QTY	FM400-23 (6899138801)	FM400-23PB (6899138301)	FM400-24 (6899138701)
	6899415901	1			
	6899413901	1			
BEARING TUBE ASSEMBLY	6899517701	1			
BEARING TUBE ASSEMBLY	6899517501	1			
ROTOR COVER	6890464701	1			
ROTOR COVER NUT	6891810401	1			
ROTOR TUBE	6890445401	1			
ROTOR BASE	6890445801	1			
NOZZLE	6890492201	2			
SEPARATION CONE	6893319301	1			
PAPER INSERT (PACK OF 25)	6893322601	1			

COVER ASSEMBLY	PART No.	QTY	FM400-23 (6899138801)	FM400-23PB (6899138301)	FM400-24 (6899138701)
	6899310901	1			
	6899313301	1			
	6899313401	1			

BAND CLAMP	PART No.	QTY	FM400-23 (6899138801)	FM400-23PB (6899138301)	FM400-24 (6899138701)
	6890335201	1			

FM400 KITS	PART No.	QTY	FM400-23 (6899138801)	FM400-23PB (6899138301)	FM400-24 (6899138701)
FILTER COVER FIXING KIT	6899716901	1			
CUT OFF VALVE KIT	6899073901	1			
SEALS KIT	6899717001	1			
CIRCLIP KIT	6899715401	1			

MANN + HUMMEL (UK) LTD.
Units 11 - 15 Chard Business Park
Leach Road, Chard
Somerset, TA20 1FA
Tel: +44 (0) 1460 238900
Fax: +44 (0) 1460 238997
Email:ocs@mann-hummel.com

MANN+HUMMEL FILTER TECHNOLOGY (S.E.A)
PTE LTD
3 Toh Tuck Link
#03-02/03 German Districentre
Singapore 596228
Tel: +65 (6465) 11 28
Fax: +65 (6465) 11 38
Email:ftsg@mann-hummel.com.sg

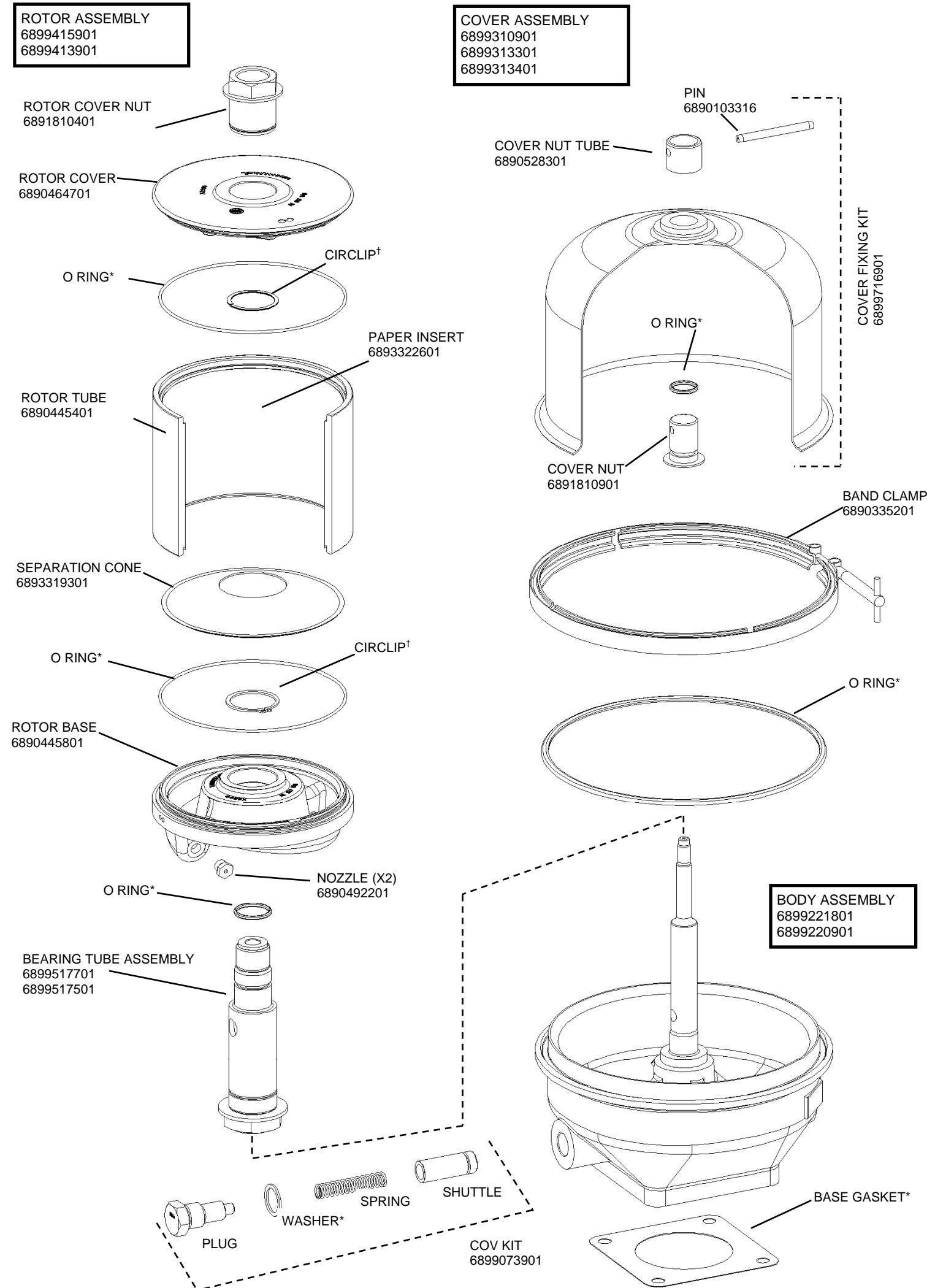

*SEALS KIT (6899717001) COMPRISES OF: C.O.V. WASHER, BODY O RING, ROTOR O RING X 2, COVER O RING AND BEARING TUBE O RING
†CIRCLIP KIT (6899715401) COMPRISES OF: BEARING TUBE CIRCLIP AND ROTOR COVER NUT CIRCLIP